

DuCoNite 25 and DuCoNite 32

Bredel

SERIES
Bredel Hose Pumps

FEATURES AND BENEFITS

- Robust design for aggressive chemicals or abrasives
- Pump protected against corrosive and caustic fluids and atmospheres by its high-tech surface treatment
- Sealless, valveless pumping principle for reliable, low maintenance metering, dosing and transfer
- Dry running and self-priming, with up to 9.5 meters (30 foot) suction lift capability
- Compact direct coupled design to maximise gearbox life
- Simple hose change decreases cost of ownership, downtime and need for parts inventory



PERFORMANCE

DuCoNite 25

Required motor power kW (hp)

1.50 (2.04hp)

1.25 (1.70hp)

1.00 (1.36hp)

0.75 (1.02hp)

0.50 (0.68hp)

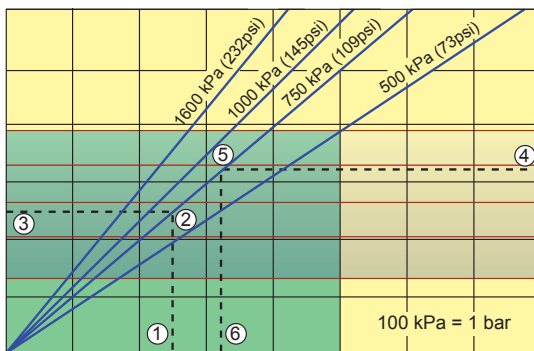

Pump speed rpm	20	40	60	80	100	120	140	160
Capacity L/h	360	720	1080	1440	1800	2160	2520	2880
Capacity USGPM	1.6	3.2	4.8	6.4	7.9	9.5	11.1	12.7

Continuous Duty
Intermittent Duty*

* Maximum 2 hours operation followed by minimum 1 hour stop

1. Flow required indicates pump speed
2. Calculated discharge pressure
3. Net motor power required
4. Product temperature
5. Calculated discharge pressure
6. Maximum recommended pump speed

DuCoNite 32

Required motor power kW (hp)

2.50 (3.40hp)

2.00 (2.72hp)

1.50 (2.04hp)

1.00 (1.36hp)

0.50 (0.68hp)

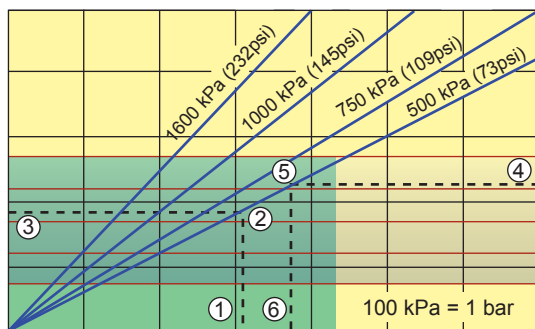

Pump speed rpm	20	40	60	80	100	120	140
Capacity L/h	750	1500	2250	3000	3750	4500	5250
Capacity USGPM	3.3	6.6	9.9	13.2	16.5	19.8	23.1

Note: The area of continuous operation diminishes with increased product temperatures.

For product temperatures >40C (104F), the area of continuous operation is limited by the corresponding red temperature line.

DIMENSIONS

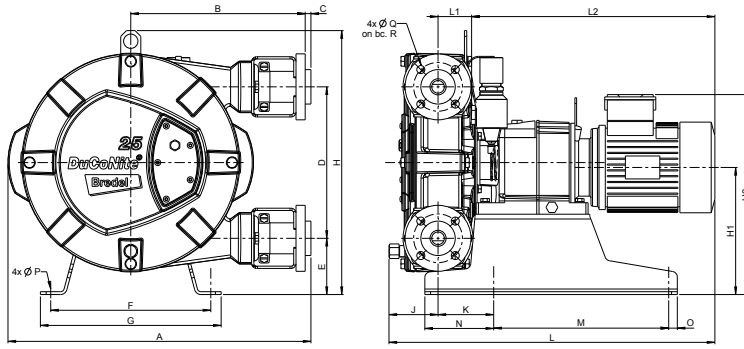

Connector sizes	ANSI 150#	EN DIN	JIS
DuCoNite 25	1"	25mm	25mm
DuCoNite 32	1.25"/1.5"	32mm	32mm

Type	A	B	C	D	E	F	G	H	H1	H2max	J	K	Lmax	L1	L2max	M	N	O	ØP	ØQ	R
DuCoNite 25 (mm)	521	304	2.5	264	98	279	315	460	222	359	66	97	592	58	468	305	120	15	12	14	85
DuCoNite 25 (inches)	20.5	12	0.09	10.4	3.9	11	12.4	18.1	8.7	14.1	2.6	3.8	23.3	2.3	18.4	12	4.7	0.6	0.47	0.6	3.3
DuCoNite 32 (mm)	631	375	2.5	330	105	324	360	538	260	402	72	93	684	68	544	370	120	20	12	18	100
DuCoNite 32 (inches)	24.8	14.8	0.09	13	4.1	12.8	14.2	21.2	10.2	15.8	2.8	3.7	26.9	2.7	21.4	14.6	4.7	0.79	0.47	0.71	3.94

TECHNICAL SPECIFICATIONS

	DuCoNite 25	DuCoNite 32
Flow range	up to 2,880 L/hr (12.7 USGPM)	up to 5,250 L/hr (23.1 USGPM)
Capacity	0.300 L/rev (0.079 G/rev)	0.625 L/rev (0.165 G/rev)
Minimum starting torque	115Nm (1018 inch-lbs)	210Nm (1859 inch-lbs)
Hose lubricant required	2.5 litres (0.66 USG)	4.5 litres (1.19 USG)
Pumphead weight	39kg (85.98lbs)	58.5kg (128.97lbs)
Max inlet pressure	3.5 bar abs (51 psia)	3.0 bar abs (44 psia)
Common features		
Suction pressure	0.05bar abs (0.73 psia)	
Maximum discharge pressure	7.5 bar (109psi)	
Product temperature range*	-10C up to 80C (14F up to 176F)	
Ambient temperature range**	-20C up to 45C (-4F up to 113F)	

*Please consult your Bredel representative for lower or higher temperature operation.

**Allowable ambient temperature is based on pump capabilities and may be further limited by gearbox ambient capabilities

MATERIALS OF CONSTRUCTION

Components	DuCoNite 25	DuCoNite 32
Pump housing	Cast iron with DuCoNite surface treatment.	
Rotor		
Cover		
Pressing shoes	Epoxy	
Brackets	Standard in AISI 316	
Flanges	Standard in AISI 316	
Inserts	AISI 316, PVC, PP, PVDF	
Support frame	Standard in AISI 316	
Hose clamps	Standard in AISI 316	
Seals	Viton or EPDM	

Options	Features
Available hose materials	NR, NR Endurance, NBR, F-NBR, EPDM, CSM
Available flanges	ANSI, EN DIN, JIS
Available inserts	Bredel standard or with sanitary connectors
High level float switch	Max 1A, 50 VA, IP65
Integrated FI for stand alone speed control	Factory programmable from 12-80 Hz
Revolution counter	For maintenance and /or metering
Insert combinations	
Hose nipple	AISI 316, PTFE, PVDF
Threaded nipple	AISI 316 BSP, AISI 316 NPT, PP NPT, PVC NPT, AISI 316 DIN 11851
Threaded nipple and flange (+nut) assembly	AISI 316 BSP nipple and Flange DIN threaded AISI 316, AISI 316 BSP nipple and Flange ASA threaded AISI 316
Flange and bracket assembly	Flange DIN AISI 316 + PP insert, Flange ASA AISI 316 + PP insert, Flange DIN AISI 316 + AISI 316 insert, Flange ASA AISI 316 + AISI 316 insert

The information contained in this document is believed to be correct at the time of publication, but Watson-Marlow Bredel BV accepts no liability for any error it contains, and reserves the right to alter specifications without prior notice. All mentioned values in this document are values under controlled circumstances at our test bed. Actual flow rates achieved may vary because of changes in temperature, viscosity, inlet and discharge pressures and/or system configuration. APEX, DuCoNite®, Bioprene® and Bredel are registered trademarks.

Bredel
Hose Pumps

wmftg.com
info@wmftg.com
+44 (0) 1326 370370